



SMART MULTIPURPOSE HUMAN ASSISTANCE ROBOT

Ms. A.V.Sindhuja¹, Mr. R.Anandan²,

Dhanalakshmi Srinivasan engineering college,

¹sindhuja0207@gmail.com, ²anandan1977@yahoo.co.in.

ABSTRACT

The project aim is to design a smart multipurpose human assistance robotic dog that needs zero maintenance. The primary purpose of this dog is to guide the visually impaired and elderly people to some predefined destination avoiding obstacles and traffic. It is also designed to act as an advanced multipurpose human assistance and service robot that is able recognize the words spoken by the user, talk to them and take action according to the spoken voice command. Voice commands are recognized by an android smart phone and the information is transferred to the main MCU using a bluetooth serial port that runs bluetooth SPP protocol stack. The robotic dog has the ability to follow a human when commanded with voice. Touch sensitive e-skin senses human finger touch and helps answering complex user requests such as time, date and weather conditions such as light and temperature. The same can be asked using voice also. It even allows the user to set wake up alarm. A built in audio playback system can play music tracks in MP3 format. One of the music tracks is kept as the alarm tone. It also plays the role of a regular watchdog during night and barks like any normal dog if it finds any abnormal activity. During the day time it can charge itself by moving around within a given region in order to find the maximum sun light, intelligently avoiding the shaded areas, thereby freeing the user completely from maintenance issues such as battery charging. It has a head; eyes and a tail like a real dog which it uses to perform special gestures during human-robot interaction.

Index Terms — Ultrasonic sensor, Capacitive Touch Keypad, MEMS, Voice Recognition Module, Solar Panel, Servo Motor, DC Motor, Robot.

1. INTRODUCTION

For many visually impaired people, a cane [3] or a stick is a close friend helping them to detect and avoid obstacles in the walking paths. During walking with the cane, they sense and guess directions and locations by hearing sounds surrounding, sniffing smells in the air, feeling touches on skin, counting footsteps they walk, and memorizing events in time and spaces. However, it is difficult for them to do this all the time when surrounding environment could suddenly change, or when they get lost memory of locations. Guide dogs are assistance dogs lead elderly or visually impaired people around obstacles. These dogs need to be trained by some special training institute and maintained healthy in order to help people. These dogs help them in one another way. Elderly people are often left alone and have least amount of interaction with other people. Although a guide dog relieve them from such a situation, they are dumb and lag intelligence of a human companion. Overcoming all these disadvantages we design a smart multipurpose human assistance robotic dog that needs zero maintenance. The primary purpose of this Robotic

dog is to guide the visually impaired and elderly people.

2. SYSTEM DESIGN

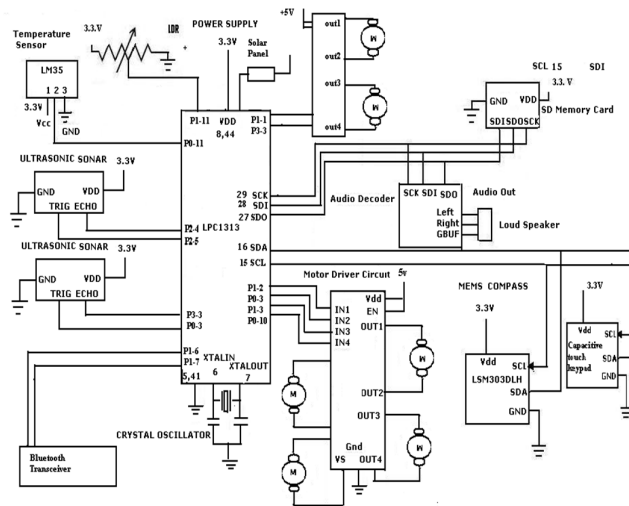

Figure1. Circuit Diagram

The Robotic dog guides the visually impaired and elderly people to some predefined destination avoiding obstacles and traffic. In this system, two ultrasonic sensors are used. The left and right side ultrasonic sensor emits the ultrasonic sound waves and are propagated through air, if there is any obstacle within the range of the sensor frequency, the sound waves are returned, and are received by the receiver ultrasonic sensor [8]. The sensory information is sent to the microcontroller (Robot side) and processes the data. It is also designed to act as an advanced multipurpose human assistance and service robot that is able to recognize the words spoken by the user, talk to them and take action according to the spoken voice command. Voice commands are recognized by an android smart phone and the information is transferred to the main MCU using a bluetooth serial port.

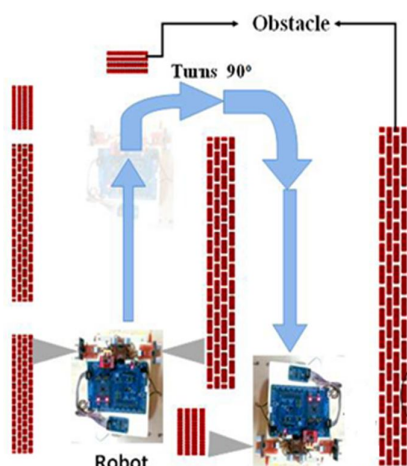

Figure 2. Robot Path Recognition

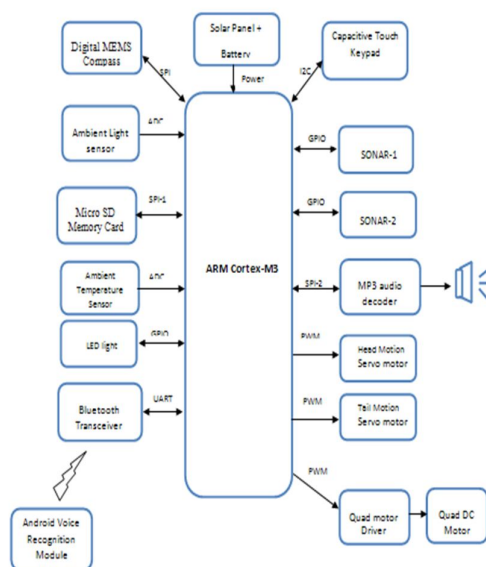

Figure 3. Block Diagram

OBSTACLE DETECTION

The obstacle can be detected by using High precision ultrasonic sonar sensor. The front sonar sensor can cover the range up to 30 cm as shown in figure 4 and left and right side sonar sensor can detect the obstacle up to the range of 60 cm [10]. If any obstacle detected, the microcontroller gives the information about the obstacle detection to the authorized person, this robot will take right side direction and proceeds forward direction. If again any obstacle is detected then data is collected from SD card and is decoded using MP3 decoder and it is sent to loudspeaker. The robotic wheel movement is done with the help of DC motors. There are four DC motors are fixed to each of the robot wheels. All the motors are connected to PWM (pulse width modulation) in the microcontroller residing at the robot and hence the direction of the robotic wheel movement is controlled.

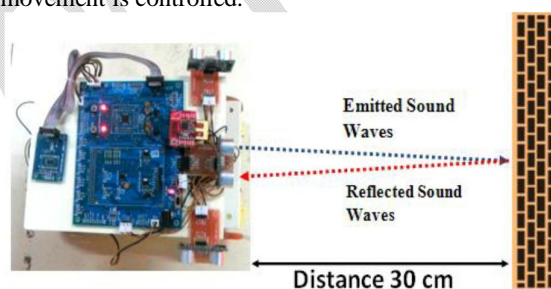

Figure 4. In-front Obstacle Detection

3. FEATURES AND DESCRIPTION

A) MICROCONTROLLER

The LPC1313 is ARM Cortex-M3 based microcontrollers for embedded applications featuring a high level of integration and low power consumption. The LPC1313 operates at CPU frequencies of up to 72 MHz. The peripheral complement of the LPC1313 includes up to 32 kB of flash memory, up to 8 kB of data memory, USB Device (LPC1342/43 only), one Fast-mode Plus I2C-bus interface, one UART, four general purpose timers, and up to 42 general purpose I/O pins. The front ultrasonic sensor is interfaced with the microcontroller's pin 19 / port 2.4, and pin 20 / port 2.5, right ultrasonic sensor is interfaced with the microcontroller's pin 46 / port 1.6 and pin 47 / port 1.7, left ultrasonic sensor is interfaced with the pin 11 / port 2.7 and pin 2.6 / port 1. RF module is interfaced with the microcontroller's pin 16, 15 and 29 to the corresponding ports SDO, SD1 and SK. And the MEMS magnetometer is interfaced with the microcontroller's port 15 and pin 0.4 and port 16 / pin 0.5. Pin diagram of LPC1313 Microcontroller is shown in figure 5.



Figure.5. ARM7 LPC1313 Microcontroller
B) L293D DRIVER

The L293D is designed to provide bidirectional drive currents of up to 600-mA at voltages from 4.5 V to 36 V. Drivers are enabled in pairs, with drivers 1 and 2 enabled by 1, 2 EN and drivers 3 and 4 enabled by 3, 4 EN. When an enable input is high the associated drivers are enabled, and their outputs are active and in phase with their inputs. When the enable input is low, those drivers are disabled, and their outputs are off and in the high-impedance state. With the proper data inputs, each pair of drivers forms a full-H (or bridge) reversible drive suitable for solenoid or motor applications [7]. Figure 6 shows motor direction control. This driver is used to control the motor residing at the robot side. And it gets PWM frequency from the microcontroller and acts upon the received frequency.

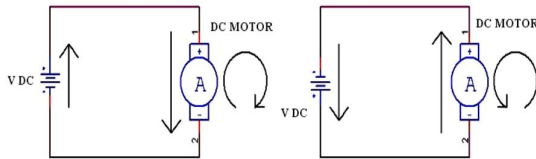

Figure.6. Motor Direction Control

C) ULTRASONIC SENSOR

The SRF02 is a single transducer ultrasonic rangefinder in a small footprint PCB. It features both I2C and a serial interfaces in Figure 7. The serial interface is a standard TTL level UART format at 9600 baud, 1 start, 2 stop and no parity bits, and may be connected directly to the serial ports on any microcontroller. Up to 16 SRF02's may be connected together on a single bus, either I2C or Serial [9]. New commands in the SRF02 include the ability to send an ultrasonic burst on its own without a reception cycle, and the ability to perform a reception cycle without the preceding burst. Because the SRF02 uses a single transducer for both transmission and reception, the minimum range is higher than our other dual transducer rangefinders [9]. The minimum

measurement range is around 15cm (6 inches). Interfacing diagram for Ultrasonic sensor with Microcontroller is shown in figure 8. In this work, the sensor is used to detect the in front obstacles and robot left and right side environments.



Figure.7.Schematic Diagram for Ultrasonic sonar sensor

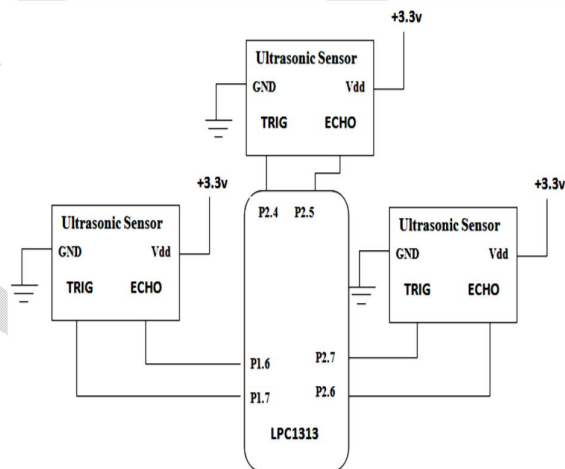

Figure 8. Interfacing diagram for Ultrasonic sensor with Microcontroller

D) MEMS

Micro Electro Mechanical System, which measures magnetic fields, is distinct from metal detectors. When used for detecting metals, a magnetometer can detect only magnetic (ferrous) metals, but can detect such metals buried much deeper than a metal detector [11]. Magnetometers are capable of detecting large objects like cars at tens of meters, while a metal detector's range is unlikely to exceed 2 meters. Schematic Diagram of MEMS Magnetometer is shown in Figure 9. Interfacing diagram of MEMS with microcontroller is shown in figure 10. The accurate position of the robot can be determined by using MEMS. It is interfaced with I2C bus in the microcontroller.

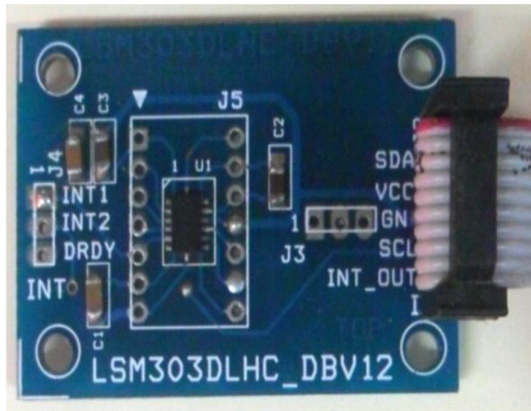

Figure.9. Schematic Diagram of MEMS Magnetometer

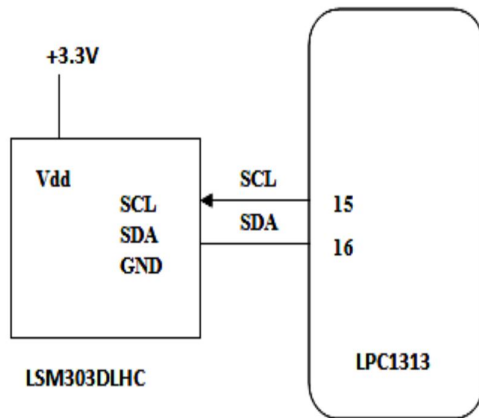

Figure.10. Interfacing diagram of MEMS with microcontroller

E) CAPACITIVE TOUCH SENSOR CONTROLLER

The MPR121 is the second generation capacitive touch sensor controller after the initial release of the MPR03x series devices. The MPR121 features increased internal intelligence, some of the major additions include an increased electrode count, a hardware configurable I2C address, an expanded filtering system with debounce, and completely independent electrodes with auto-configuration built in. The device also features a 13th simulated sensing channel dedicated for near proximity detection using the multiplexed sensing inputs.

F) TEMPERATURE SENSOR (MCP9800)

The MCP9800 is a digital temperature sensor capable of reading temperatures from -55°C to +125°C. Temperature data is measured from an integrated temperature sensor and converted to digital word with a user selectable 9 to 12-bit Sigma Delta Analog to Digital Converter. The MCP9800 notifies the host controller when the ambient

temperature exceeds a user programmed set point. The ALERT output is programmable as either a simple comparator for thermostat operation or as a temperature event interrupt. Communication with the sensor is accomplished via a two-wire bus that is compatible with industry standard protocols. This permits reading the current temperature, programming the set point and hysteresis and configuring the device. Small physical size, low installed cost and ease of use make the MCP9800 an ideal choice for implementing sophisticated temperature system management schemes in a variety of applications.

G) SOLAR PANEL

A solar panel is a set of solar photovoltaic modules which is electrically connected and mounted on a supporting structure. A photovoltaic module is a packaged, connected assembly of solar cells. The solar panel can be used as a component of a larger photovoltaic system to generate and supply electricity in commercial and residential applications. Each module is rated by its DC output power under standard test conditions. Solar modules use light energy (photons) from the sun to generate electricity through the photovoltaic effect. The majority of modules use wafer based crystalline silicon cells or thin film cells based on cadmium telluride or silicon. The structural (load carrying) member of a module can either be the top layer or the back layer. Cells must also be protected from mechanical damage and moisture. Most solar modules are rigid, but semi-flexible ones are available, based on thin-film cells. Electrical connections are made in series to achieve a desired output voltage in parallel to provide a desired current capability. The conducting wires that take the current off the modules may contain silver, copper or other non-magnetic conductive transition metals

H) DC MOTOR

A DC motor is a mechanically commutated electric motor powered from direct current (DC). The stator is stationary in space by definition and therefore its current. The current in the rotor is switched by the commutator to also be stationary in space. This is how the relative angle between the stator and rotor magnetic flux is maintained near 90 degrees, which generates the maximum torque in figure 11. Different connections of the field and armature winding provide different inherent speed/torque regulation characteristics. The speed of a DC motor can be controlled by changing the voltage applied to the armature or by changing the field current [2]. Interfacing diagram for motor control with Microcontroller is shown in figure 12. The robot is moved by using DC motors and this motor is connected to the L293D driver. This driver gets the PWM frequency and actuates the wheel movement. There are four motors are used to move the robot at desired direction.

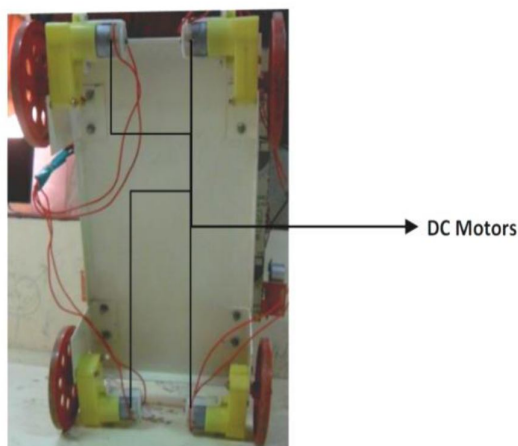

Figure.11 DC motors

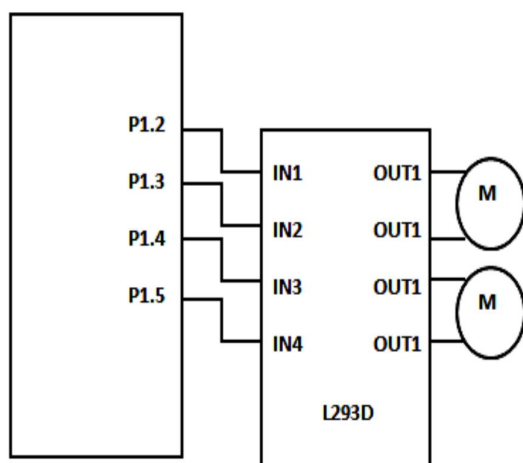

Figure.12. Interfacing diagram for motor control with Microcontroller

4. WORKING

Necessary library files are included in the microcontroller. The protocols SPI, I2C, UART and Bluetooth wireless module is initialized for communication through android voice recognition. Microcontroller waits for user command through android module or capacitive touch keypad. When microcontroller receives the watchdog command, ultrasonic sensor is turned ON and starts sensing the obstacle, if the obstacle is detected then data is collected from SD card and is decoded using MP3 decoder and it is sent to loudspeaker. When the command is about temperature information through capacitive touch keypad then temperature is sensed using temperature sensor and the information is collected from SD card and is decoded using MP3 decoder and it is sent to loudspeaker. When follow me voice command is given using wireless Bluetooth of android phone, the voice input is received in the microcontroller then ultrasonic sensor is turned ON and it senses the user. Four DC

motors of the robotic dog are turned ON based on the output signal of ultrasonic sensor. In the capacitive touch keypad if key 1 is pressed, head motion servomotor is turned ON and if key 1 is pressed, tail motion servomotor is turned ON. When battery is low, the robotic dog starts moving randomly and searches for sunlight, when the incoming signal from the solar panel is high at that point robotic dog stops and gets charged. So the user is free from maintenance issues like battery charging.

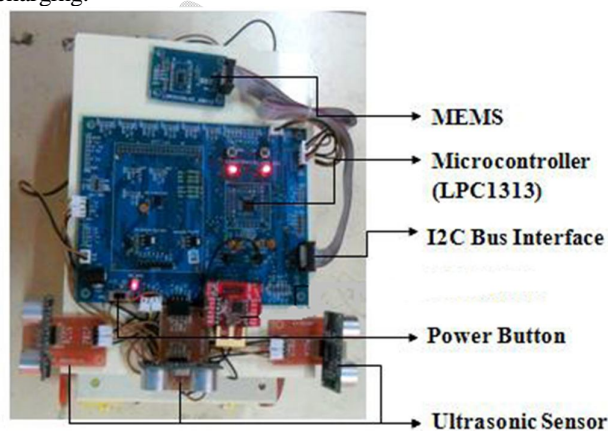

Figure.13. Prototype of the Robot

6. CONCLUSION

In this paper a new smart multipurpose human assistance robot that needs zero maintenance. The primary purpose of this dog is to guide the visually impaired and elderly people to some predefined destination avoiding obstacles and traffic. It is also designed to act as an advanced multipurpose human assistance and service robot that is able recognize the words spoken by the user, talk to them and take action according to the spoken voice command. Voice commands are recognized by an android smart phone and the information is transferred to the main MCU using a bluetooth serial port that runs Bluetooth SPP protocol stack. Touch sensitive e-skin senses human finger touch and helps answering complex user requests such as time, date and weather conditions such as light and temperature. The same can be asked using voice also. It even allows the user to set wake up alarm. A built in audio playback system can play music tracks in MP3 format. Low power 32-bit ARM Cortex-M3 microcontroller enables highly deterministic operation using battery power only. It also plays the role of a regular watchdog during night and barks like any normal dog if it finds any abnormal activity. During the day time it can charge itself by moving around within a given region in order to find the maximum sun light, intelligently avoiding the shaded areas, thereby freeing the user completely from maintenance issues such as battery charging. It has a head eyes and a tail like a real dog which it uses to perform special

gestures during human-robot interaction. Capacitive Touch keypad eliminates finger pain while using older Braille keys and allows blind people to enter notes and control device operation easily. 100% hands free operation using voice recognition facility. Sun finding based intelligent charging eliminates maintenance issues.

ACKNOWLEDGEMENT

I would like to thank Mr.R.Anandan, Associate professor in Dhanalakshmi Srinivasan College of Engineering and Technology for guiding me to bring this paper successfully.

REFERENCES

- [1] S. Ueki, H. Kawasaki, S. Ito, Y. Nishimoto et al., "Development of a hand-assist robot with multi-degrees-of-freedom for rehabilitation therapy," *IEEE/ASME Trans. Mechatronics* [Online]. Available: <http://ieeexplore.ieee.org>, DOI: 10.1109/TMECH.2010.2090353.
- [2] K. Kiguchi, K. Iwami, M. Yasuda, K. Watanabe, and T. Fukuda, "An exoskeletal robot for human shoulder joint motion assist," *IEEE/ASME Trans. Mechatronics*, vol. 8, no. 1, pp. 125–135, Mar. 2003.
- [3] K. Kiguchi, T. Tanaka, and T. Fukuda, "Neuro-fuzzy control of a robotic exoskeleton with EMG signals," *IEEE Trans. Fuzzy Syst.*, vol. 12, no. 4, pp. 481–490, Aug. 2004.
- [4] M. Mihelj, T. Nef, and R. Riener, "ARMin II—7 DOF rehabilitation robot:Mechanics and kinematics," in *Proc. IEEE Int. Conf. Robot. Autom.*, Roma, Italy, Apr. 2007, pp. 4120–4125.
- [5] J. C. Perry, J. Rosen, and S. Burns, "Upper-limb powered exoskeleton design," *IEEE/ASME Trans Mechatronics*, vol. 12, no. 4, pp. 408–417, Aug. 2007.
- [6] K. Kong and D. Jeon, "Design and control of an exoskeleton for the elderly and patients," *IEEE/ASME Trans. Mechatronics*, vol. 11, no. 4, pp. 428–432, Aug. 2006.
- [7] G. S. Sawicki, K. E. Gordon, and D. P. Ferris, "Powered lower limb orthoses: Applications in motor adaptation and rehabilitation," in *Proc. IEEE Int. Conf. Rehabil. Robot.*, 2005, pp. 206–211.
- [8] C. Fleischer and G. Hummel, "Embedded control system for a powered leg exoskeleton," in *Embedded Systems—Modeling, Technology, and Applications*. New York: Springer-Verlag, 2006, pp. 177–185.
- [9] C. Mavroidis, J. Nikitczuk, B. Weinberg, G. Danaher, K. Jensen, P. Pelletier, J. Prugnarola, R. Stuart, R. Arango, M. Leahey, R. Pavone, A. Provo, and D. Yasevac, "Smart portable rehabilitation devices," *J. Neuroeng. Rehabil.*, vol. 2, no. 1, pp. 18–32, 2005.
- [10] K. Kasaoka and Y. Sankai, "Predictive control estimating operator's intention for stepping-up motion by exo-skeleton type power assist system HAL," in *Proc. IEEE/RSJ Int. Conf. Intell. Robots Syst.*, Oct. 2001, Maui, HI, pp. 1578–1583.
- [11] T. Hayashi, H. Kawamoto, and Y. Sankai, "Control method of robotic suit HAL working as operator's muscle using biological and dynamical information," in *Proc. IEEE/RSJ Int. Conf. Intell. Robots Syst.*, 2005, pp. 3455–3460.
- [12] K. Yamamoto, M. Ishii, K. Hyodo, T. Yoshimitsu, and T. Matsuo, "Development of power assisting suit (miniaturization of supply system to realize wearable suit)," *JSME Int. J., Ser. C*, vol. 46, no. 3, pp. 923–930, 2003.
- [14] Kohei Wakita, Jian Huang, *Member, IEEE*, Pei Di, Kosuke Sekiyama, and Toshio Fukuda, *Fellow, IEEE* "Human-Walking-Intention-Based Motion Control of an Omnidirectional-Type Cane Robot " *IEEE/ASME transactions on mechatronics*, vol. 18, no. 1, february 2013.
- [15] Takeshi Ando, *Member, IEEE*, Ryota Tsukahara, Masatoshi Seki, and Masakatsu G. Fujie, *Senior Member, IEEE* "A Haptic Interface "Force Blinker 2" for Navigation of the Visually Impaired *IEEE TRANSACTIONS on industrial electronics*, vol. 59, no. 11, November 2012.